

DRIVE TECHNOLOGY ▷ LINEAR ▷ ROTARY ▷ DIRECT ▷ CONVENTIONAL

TAKE THE LEAD

LINEAR MOTION
TECHNOLOGY GMBH



STANDARD LINEAR MOTOR SYSTEMS
LMS M SERIES

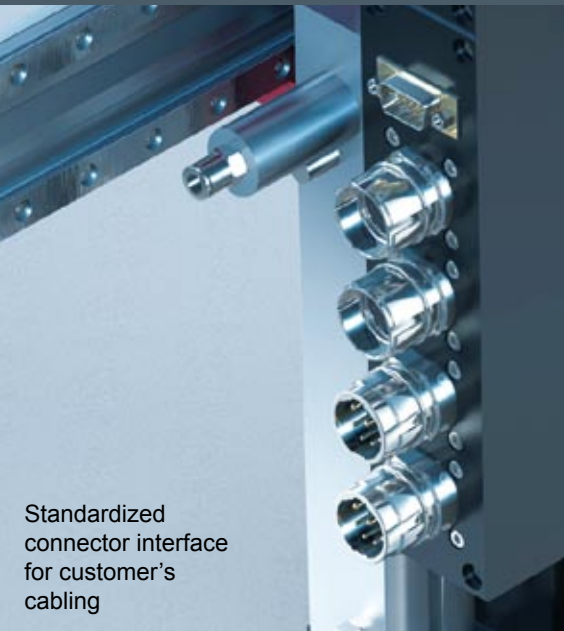

Standardized connector interface for customer's cabling

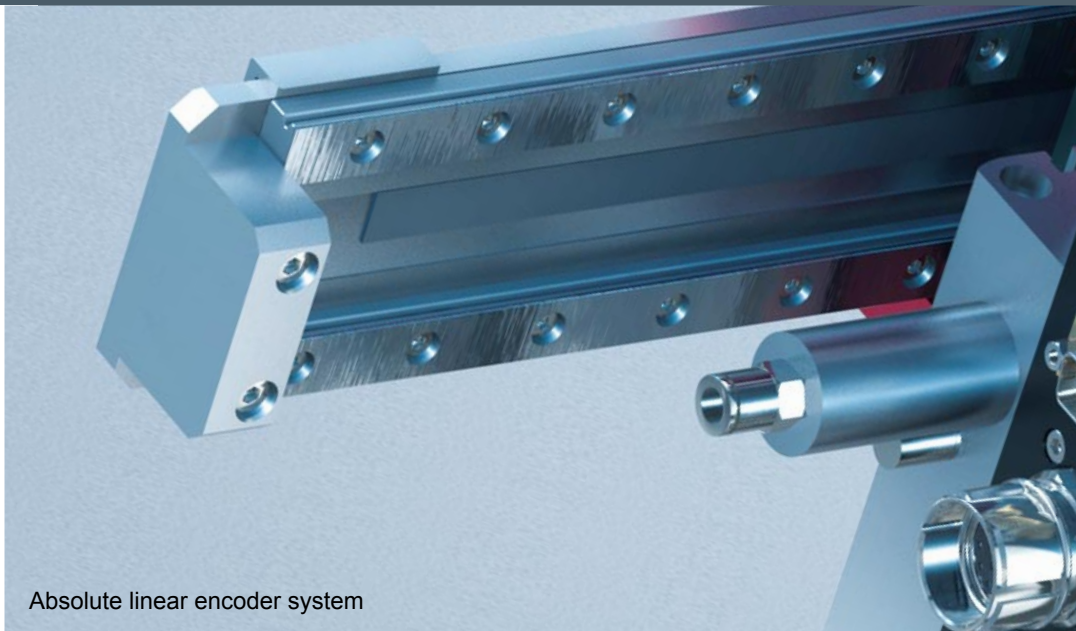

Absolute linear encoder system



Mass balancing

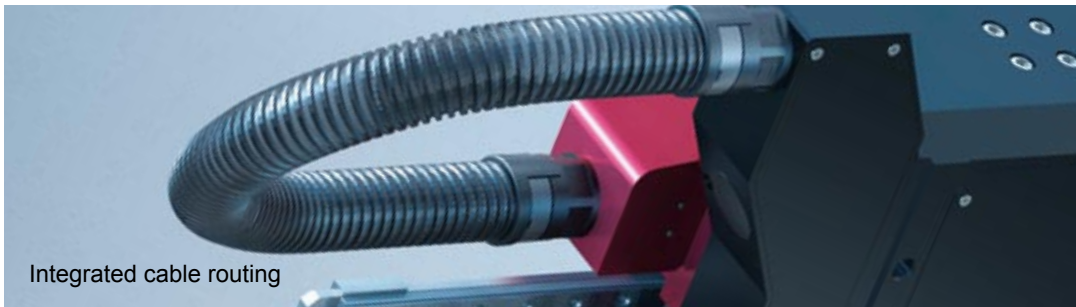

Integrated cable routing

LMS M

Production quantity: IMPROVE
Process quality: IMPROVE
Machine uptime: IMPROVE
Energy efficiency: IMPROVE

These are some arguments for replacing existing pneumatic and electrical handling units by the high-performance LMS M series by KML.

The combined LMS M linear motor system has two crosswise axes that are directly connected to each other for mass optimization purposes. The very compact and integral design with inherent stability is suitable for both vertical applications (Z/Y axes) and horizontal compound table applications (X/Y axes). Small and medium loads can be positioned with highest dynamics and precision in a working range of 150 x 400 mm. The desired position can be reliably maintained by using the weight compensation option and a brake system without current being supplied. The extensive range of options enables a large number of applications.



LINEAR MOTOR SYSTEM LMS M: MULTIFUNCTIONAL

Cycle time of 0.35 s = highest productivity

Cost efficiency in two axes

Characteristics:

- Cycle time of 0.35 s (@ 300 x 100 mm)
- Absolute linear encoder system*
- Pneumatic weight compensation*
- Brake system*
- Lifetime lubrication
- Cleanroom version*
- Protection up to IP65*
- Flexible interface connection
- Tool connector*
- Connector interface
- Flexible controller options
- Attractive price/performance ratio

* optionally available

Fields of application:

- High speed pick & place
- High speed assembly
- Dispensing
- Test units (permanent test benches)
- Cycle type systems
- Handling
- Feeding systems
- Compound table applications



ADVANTAGES OF THE LMS M LINEAR MOTOR SYSTEMS COMPARED TO CONVENTIONAL HANDLING SYSTEMS

- Matched components as well as optionally available control electronics and basic parameters for plug & play reduce commissioning time
- Lifetime lubrication:
 - no relubrication units
 - reduced implementation time
 - no maintenance time
- Pneumatic weight compensation for optimum operating characteristics compared to steel spring systems
- Encapsulated components offer IP65 protection
- Version with corrosion-resistant components and lubricants for cleanroom applications
- No reference run is necessary thanks to the integrated absolute linear encoder system
- Compact, integral design with inherent stability
- Reduced energy consumption compared to pneumatic axis systems (particularly when calculated over lifetime)
- Various electronic control components enable maximum flexibility to any user
- Left-hand and right-hand version available

Technical data

Z stroke (vertical):	0 – 100 mm (150 mm)	Max. customer load LMS M-10:	5 kg
Y stroke (horizontal):	0 – 400 mm	Max. customer load LMS M-30:	10 kg
Positioning accuracy:	± 0.010 mm	Feedback signals:	1Vss, TTL, SSI + 1Vss, EnDat
Repeat accuracy:	± 0.003 mm	Protection class:	up to IP65
Max. acceleration:	60 m/s ²	Relubrication interval:	5 years or 20 000 km
Max. velocity:	4.8 m/s	Installation positions:	horizontal/vertical
		Weight compensation:	mechanic, pneumatic, magnetic

LMS M-10 Z axis

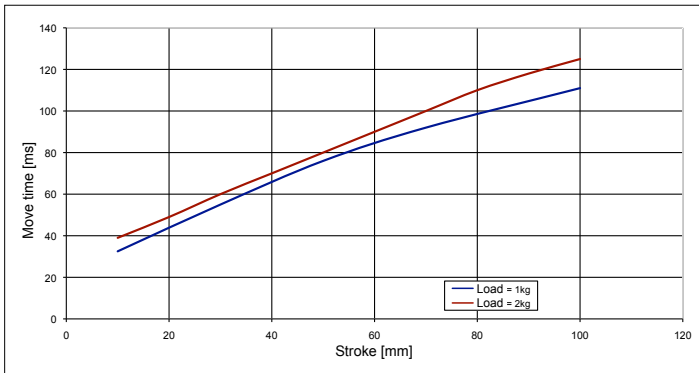

LMS M-10 Y axis

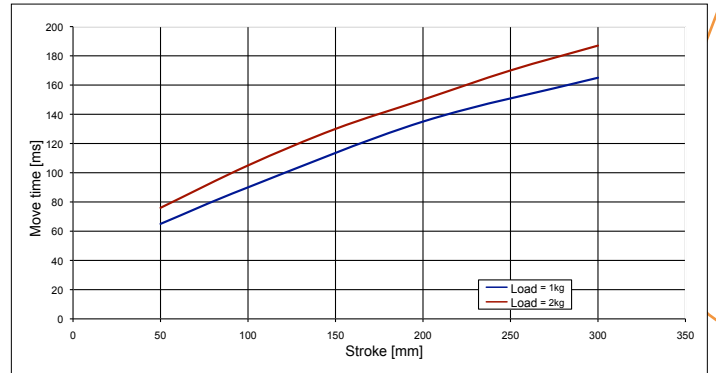

LMS M-30 Z axis

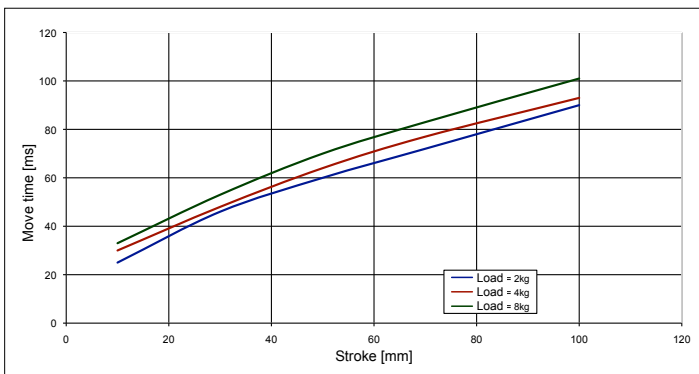

LMS M-30 Y axis

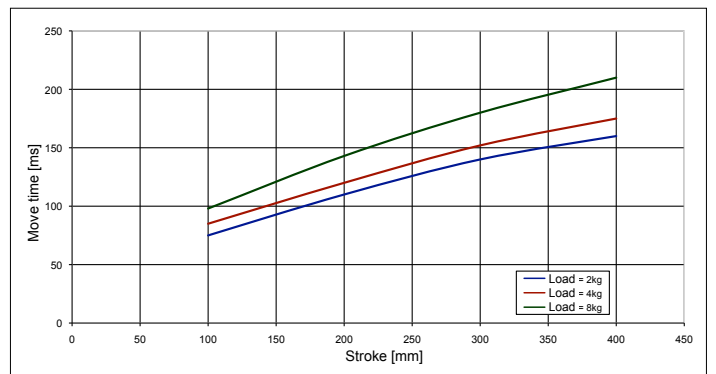

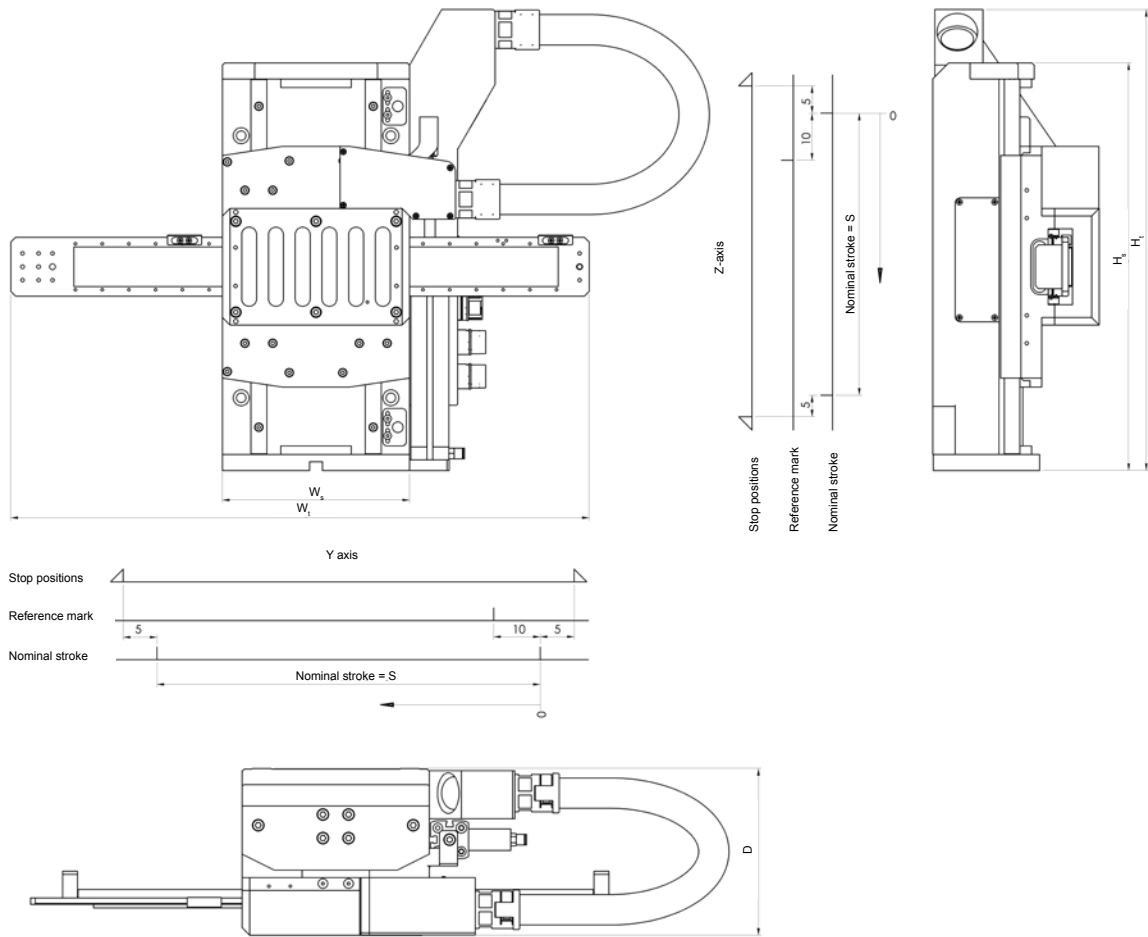

Dimensions:

Size	Depth D [mm]	Structure height H _s [mm]	Total height H _t [mm]	Structure width W _s [mm]	Total width W _t [mm]
M-10D	156	381	431	175	B _G = S _Y + 241
M-30D	181	498	548	225	B _G = S _Y + 303

Available nominal strokes Y axis S _Y [mm]					Available nominal strokes Z axis S _Z [mm]				
M-10D	100	150	200	250	300	M-10D	50	100	(150*)
M-30D	100	200	300	400		M-30D	100	(150*)	

* upon request

Technical data:

Size	Continuous feed force [N]		Peak feed force [N]	
	Y-Achse	Z-Achse	Y-Achse	Z-Achse
M-10D	100	200	270	540
M-30D	300	600	900	1740

- S Corrosion protection**
- S Limited corrosion protection
 - Exposed aluminum components: anodized
 - Steel components: bright or gun metal finished
 - Sheet metal components: stainless steel
 - Guiding system: normal steel
 - C Extensive corrosion protection
 - All aluminum components: anodized
 - Steel components: stainless steel
 - Sheet metal components: stainless steel
 - Guiding system: stainless steel or coated

Cleanroom version upon request

A09 Output signal, encoder pitch and signal period of the linear encoder system Table 5

	Output signal	Encoder pitch	Signal period	Principle
A01	1Vss	20 µm	20.00 µm	optical
A02	TTL	20 µm	5.00 µm	optical
A03	TTL	20 µm	1.00 µm	optical
A04	TTL	20 µm	0.50 µm	optical
A05	TTL	20 µm	0.20 µm	optical
A06	TTL	20 µm	0.10 µm	optical
A07	TTL	20 µm	0.05 µm	optical
A09	1Vss	1000 µm	40.00 µm	inductive
A12	1Vss	500 µm	20.00 µm	inductive
A13	EnDat 2.2	Resolution: 0.001 µm		optical
A14	SSI + 1Vss	1000 µm	40.00 µm	inductive

P0050 Accuracy class of the linear encoder system Table 6

	Accuracy [µm/1000mm]	A01	A02	A03	A04	A05	A06	A07	A09	A12	A13	A14
P0030	±3	X	X	X	X	X	X	X				
P0050	±5	X	X	X	X	X	X	X	X	X	X	X
P0100	±10								X	X		
P0200	±20								X	X		

- CD1/4 Counting direction of the linear encoder system**
- CD1/4 Y axis counts from right to left, positive.
Z axis counts from top to bottom, positive.
 - CD2/3 Y axis counts from left to right, positive.
Z axis counts from bottom to top, positive.
 - CDS Counting direction according to customer's request.
(Elevation view of the system: connectors point to the right.)

LR1 **Position of the reference point**

LR0 Without reference point
LR1 10 mm before the negative limit switch
LR2 In the center of the stroke
LR3 10 mm before the positive limit switch
LRS Reference point position according to customer's request

LS0 **Limit switch**

LS0 Without limit switch
LS1 PNP break function on both sides
LSS Special limit switch type to be defined by the customer

SB0 **Holding brake**

SB0 Without holding brake
SBS Spring-activated holding brake, opening pneumatically

GC0 **Weight compensation**

GC0 Without weight compensation
GCS Weight compensation by means of a spiral spring
GCP Weight compensation by means of a pneumatic cylinder

S **Special version**

For some configurations (XXXXX/XXXXX, LRS, LSS), an S must be added to the end of the type code.

Possible additional special versions:

- Version with increased running accuracy of the guideways
- Sealing air connection
- Special custom mounting hole pattern
- Special customized solutions on request

Please fax to: +43 1 641 50 30-51

Design specification linear motor handling Y/Z				
Customer		Fax		
Contact		E-mail		
Project/application		Road		
Telephone		Postal code, town		
	Symbol	Y (horizontal)	Z (vertical)	Unit
Process data				
Installation position	[--]			[--]
Operating time/day	t			[h]
Desired service life	L_n			[h]
Process data				
Stroke	S_{total}			[mm]
Combined motion Y/Z	$S_{comb.}$			[mm]
Velocity	V			[m/s]
Acceleration	accel			[m/s ²]
Deceleration	decel			[m/s ²]
Dwell time	t_{dwell}			[s]
Load cycles/minute	n_1			[1/min]
Motion profile	[--]			[--]
Customer mass in motion	m			[kg]
Press-in forces	F			[N]
Repeatability	[--]			[μm]
Feedback (abs./incr.)	[--]			[--]
Interface (EnDat, 1Vss, ...)	[--]			[--]
Holding brake	[--]	X		[--]
Mass balancing	[--]	X		[--]
Periphery				
Ambient temperature	T			[°C]
Cleanroom class	[--]			[--]
Protection class IP...	[--]			[--]
Supply voltage	[--]			[V]
Control	[--]			[--]
Administrative				
Number of pieces/machine	[--]			[pcs]
Annual requirement	[--]			[pcs]
Training	[--]			[--]
Target price	[--]			[€]

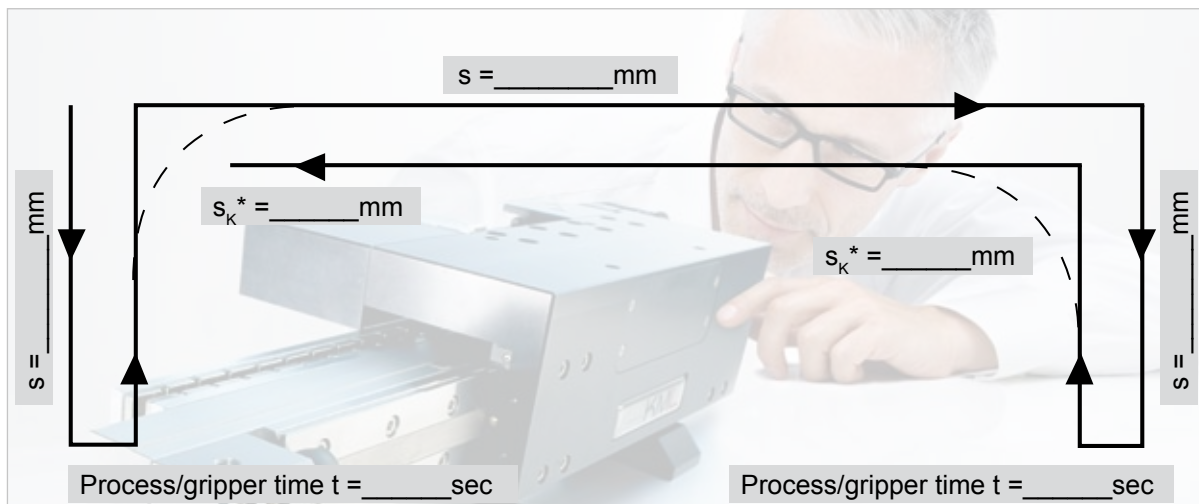

* combined motion (Y&Z)



STANDARD LINEAR MOTOR SYSTEMS AND TORQUE MOTORS, RDD SERIES

Standard linear motor systems

Dynamic, precise, plug & play, providing low maintenance and process safety: Our standard linear motor systems LMS 2, LMS E², LMS U, LMS V and LMS M have been designed to enable accurate and highly dynamic positioning of a wide range of loads.

Each series features a multitude of different characteristics, offering particular advantages for the requirements of the various applications.

All the models distinguish themselves by their high performance, positioning accuracy and compact design. They are available in different sizes and performance classes with appropriate accessories, thus perfectly matching your specific needs.

RDD torque motors

The torque motors of the RDD series are provided with a hollow shaft, either stationary or movable as required, and have a very high power density. This permanently ensures precise motion and positioning even with high continuous or peak torques combined with high speeds. The standard version includes three sizes with different power options.

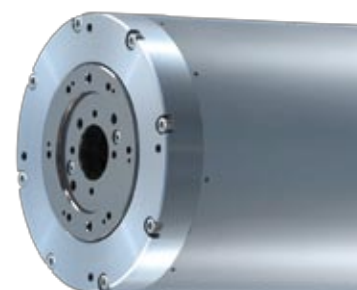

RDD

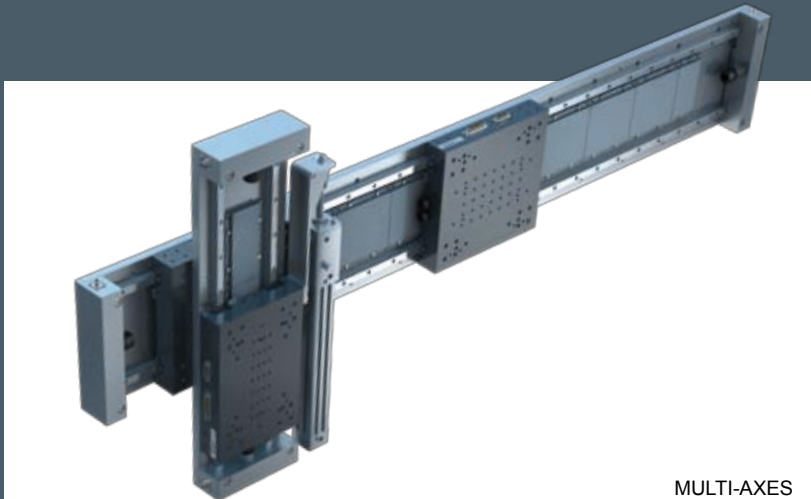

MULTI-AXES



ROBOT

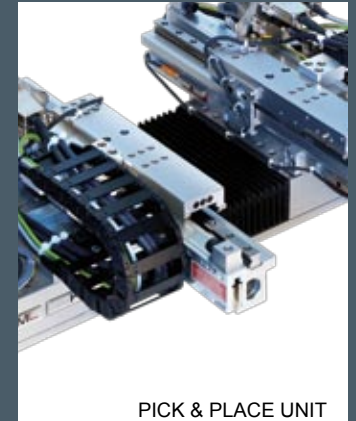

PICK & PLACE UNIT

➤ MULTI-AXIS SOLUTIONS AND INDIVIDUAL CUSTOMIZED SOLUTIONS

All linear motor systems and torque motors also possible as multi-axis solutions

All standard linear motor systems and torque motors can also be combined to form multi-axis solutions with energy chains, cables and conductors ready to plug in. This fact makes them perfectly suitable for almost unlimited applications. Further advantages are provided by the use of standardized drives and motion controllers which have been tested and qualified in conjunction with the KML product range.

Individual customized solutions

Anything is possible: In addition to the extensive standard range, we develop individual, tailor-made solutions, precisely optimized with respect to your requirements in order to accomplish your specific tasks with maximum performance. From prototype development to series production, we focus on close cooperation with you to design custom systems to meet all your needs and suit your ideas. A comprehensive modular system of standard products enables us to offer cost-efficient and prompt solutions.



TAKE THE LEAD

WITH CONFIDENCE & CERTAINTY.



ABSOLUTE RELIABILITY TO INCREASE YOUR COMPETITIVENESS: For more than 15 years, we have been developing, producing and distributing high-quality, innovative system solutions. Our aim is to meet your individual needs and to fulfil and even exceed your personal requirements.

Confidence, fairness and certainty are our basic values when dealing with our business partners. On this basis, we provide practical and economic solutions with future-

oriented technology. Consistently pursuing this goal, the name of KML Linear Motion Technology is associated with competence, innovation and reliability by our customers.

Experience provides confidence. In this spirit, we make a significant contribution to your success, allowing both of us to take the lead.

Take the lead – with confidence and certainty.



KML Linear Motion Technology GmbH

Headquarters

Daumegasse 1–3, A-1100 Wien

Phone: +43 1 641 50 30-0

Fax: +43 1 641 50 30-50

E-mail: office@kml-technology.com

www.kml-technology.com

For all further subsidiaries and contacts, please refer
to our website: www.kml-technology.com/en/contact

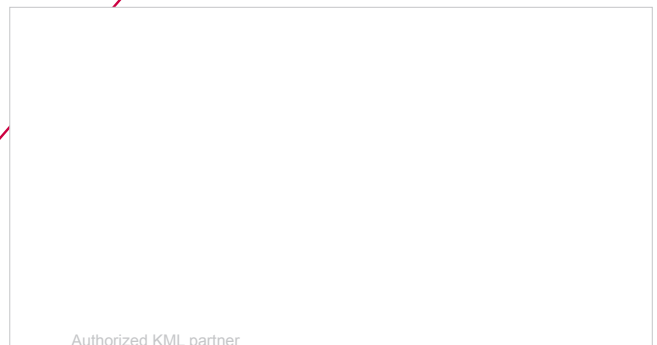

Authorized KML partner

